

Connecting the THP-700RTS to a Telephone and Radio Console - Summary

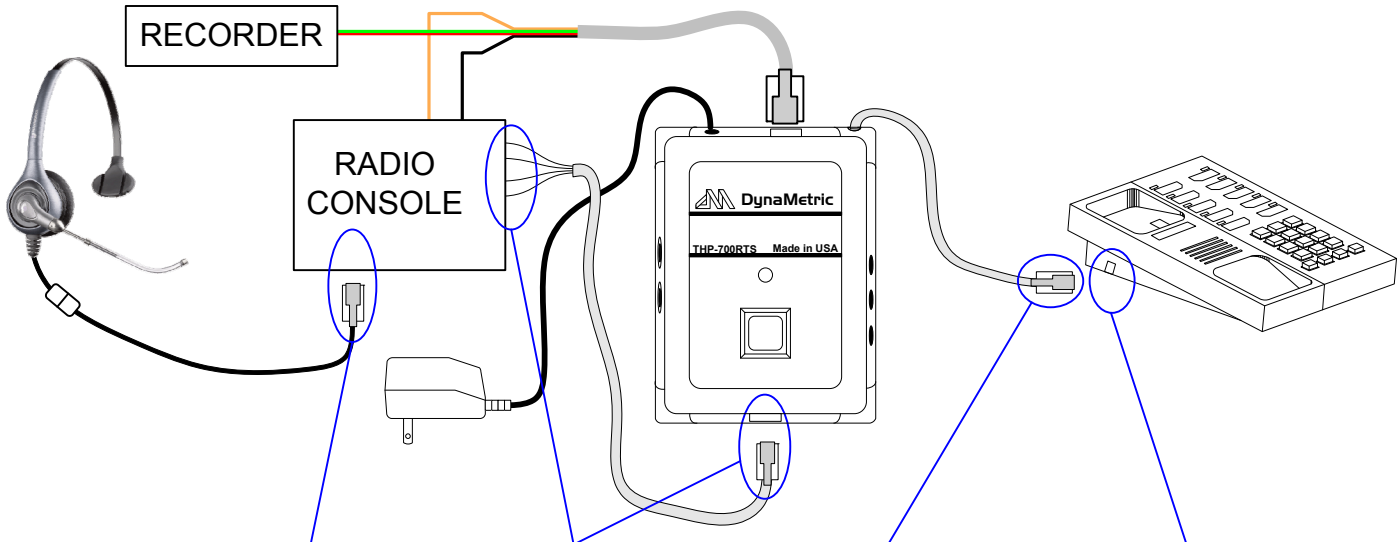

PIN	HEADSET	PIN	700RTS JACK†	PIN	700RTS PLUG*	PIN	PHONE JACK
1		1	MIC	1	Make same as Phone Jack	1	
2		2	EAR	2		2	
3		3	EAR	3		3	
4		4	MIC	4		4	

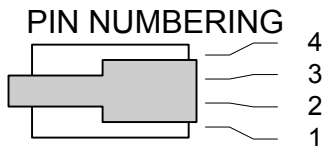

*Modifiable by rewiring modular plug.

†These functions must be on these pins.

1. Determine the pinouts of the headset cable and wire the headset jack on the radio console so they match. Be sure to get the polarity of the MIC pins correct or the mic will not work, or be very low and distorted. Test to make sure you can transmit & receive on the radio with the headset.
2. Determine the telephone headset pinouts (which function connects to each pin). If they do not coincide with the 700RTS JACK functions shown in the table above then rewire the modular plug so that they do. Plug the 700RTS into the phone headset jack and connect the 700RTS power supply.
3. Make & connect an RJ11 cable to plug into the top jack of the 700RTS: pins 2&5 are contact closure from the 700RTS to request headset use, and pins 3&4 are audio output to recorder.
4. Build and connect the modular cable that connects the 700RTS to the radio console, keeping in mind the functions connected to each pin as shown in the **700RTS JACK** section of the table above. Be sure to observe the polarity of the MIC lines.

See the following pages for more details.

Connecting the Headset to the Radio Console

The headset must be electrically compatible with both the radio and the phone. The headset is connected directly to the radio console, which has switching circuits to connect it to the radio & phone. In most cases, when the headset is switched to the phone, received radio audio is switched to the console speaker so the operator can still hear the radio traffic.

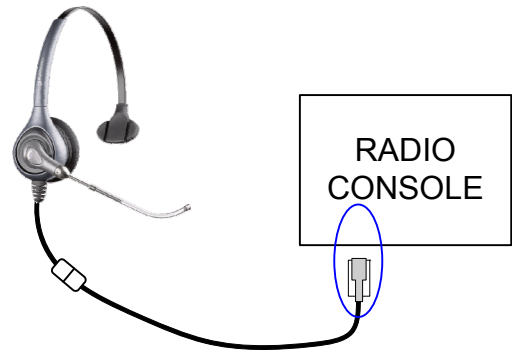

The radio engineer will have to design an interface between the headset and the radio and make sure that it is working properly, and that the headset is compatible with the radio mic & earphone circuits.

Determining the Telephone Jack's Pinouts

In most cases, the Headset jack on the telephone will be used for connection to the radio system, leaving the telephone's Handset available for local use.

You must determine which function connects to which of the 4 pins of the phone's headset jack. It would be nice if they were all standard but they certainly are NOT.

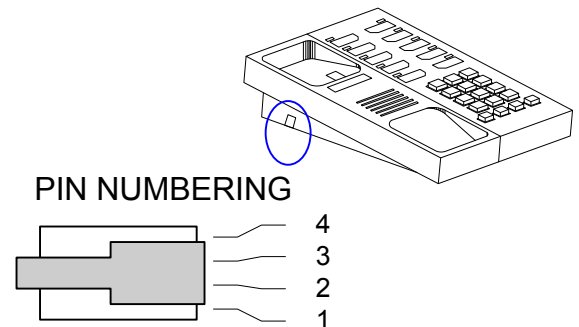

The purpose for this is that the THP-700RTS needs to have the correct connections for its sensing and switching functions. See the examples of what you may find on your phone's headset jack below:

Example 1

PIN	PHONE JACK
1	MIC
2	EAR
3	EAR
4	MIC

Example 2

PIN	PHONE JACK
1	EAR
2	MIC
3	MIC
4	EAR

Modifying the Modular Plug on the THP-700RTS (if necessary)

Example 1

PIN	700RTS JACK†	PIN	700RTS PLUG*	PIN	PHONE JACK
1	MIC	1	Make same as 700RTS plug	1	MIC
2	EAR	2		2	EAR
3	EAR	3		3	EAR
4	MIC	4		4	MIC

Note that in the case of Example 1 above, the functions of the phone jack pins match the functions of the 700RTS jack pin-for-pin. This means no modification of the 700RTS plug is necessary.

Example 2

PIN	700RTS JACK†	PIN	700RTS PLUG*	PIN	PHONE JACK
1	MIC	1	Make same as Phone Jack	1	EAR
2	EAR	2		2	MIC
3	EAR	3		3	MIC
4	MIC	4		4	EAR

*Modifiable by rewiring modular plug.

†These functions must be on these pins.

In Example 2 above, the functions between the phone jack and the 700RTS are on different pins. This will require modifying the connections to the modular connector on the 700RTS cable, in this case, switching the Green & Yellow, and Red & Black will accomplish the modification.

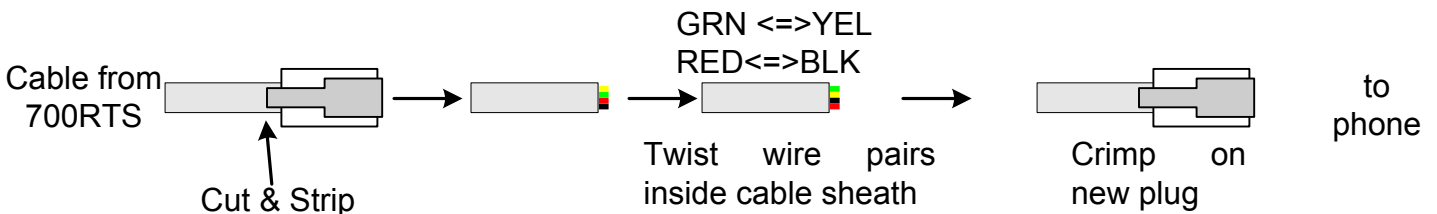

In the case of Example 2 above, DynaMetric has an adapter cable, CBL-50, that performs the same function as the cable modification above.



Connecting the THP-700RTS to the Radio Console - Part 1

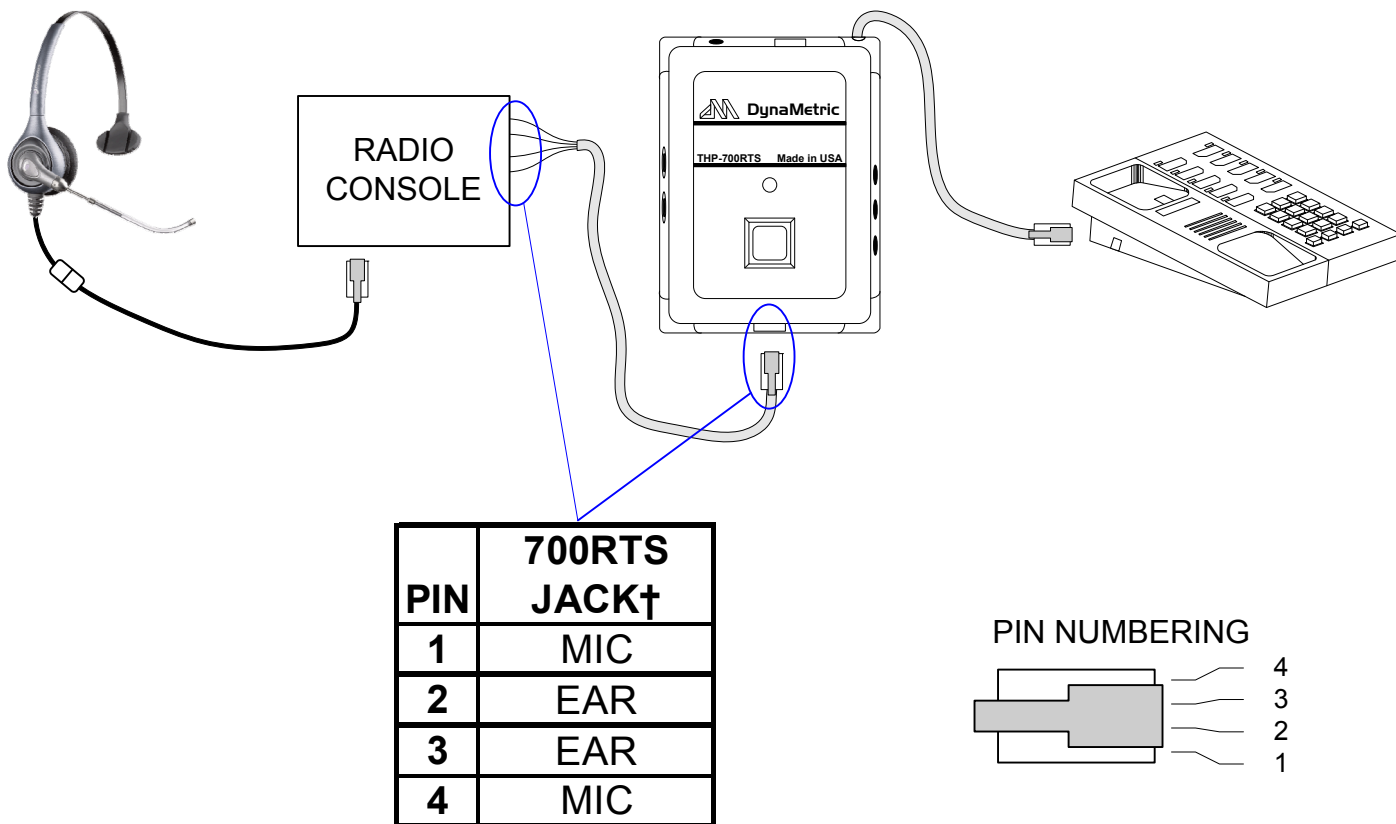

†These functions must be on these pins.

A cable must now be made to bring the 4 switched headset connections from the radio console to the THP-700RTS. The plug is a 4 position 4 conductor modular plug (4P4C, handset size).

The diagram shows which functions must be on which pins for compatibility with the 700RTS.

IMPORTANT - MIC Polarity: The 700RTS doesn't care about the polarity of the MIC connections but the phone & headset do. As you build this cable, take the MIC voltage polarity into consideration: make sure MIC+ and MIC- end up on the correct pins of the cable that connects to the phone headset jack. While the headset is connected to the phone, the phone provides power for the headset microphone. If the MIC polarity is connected wrong, the mic will not work, or be very low and distorted on phone conversations.

Connecting the THP-700RTS to the Radio Console - Part 2

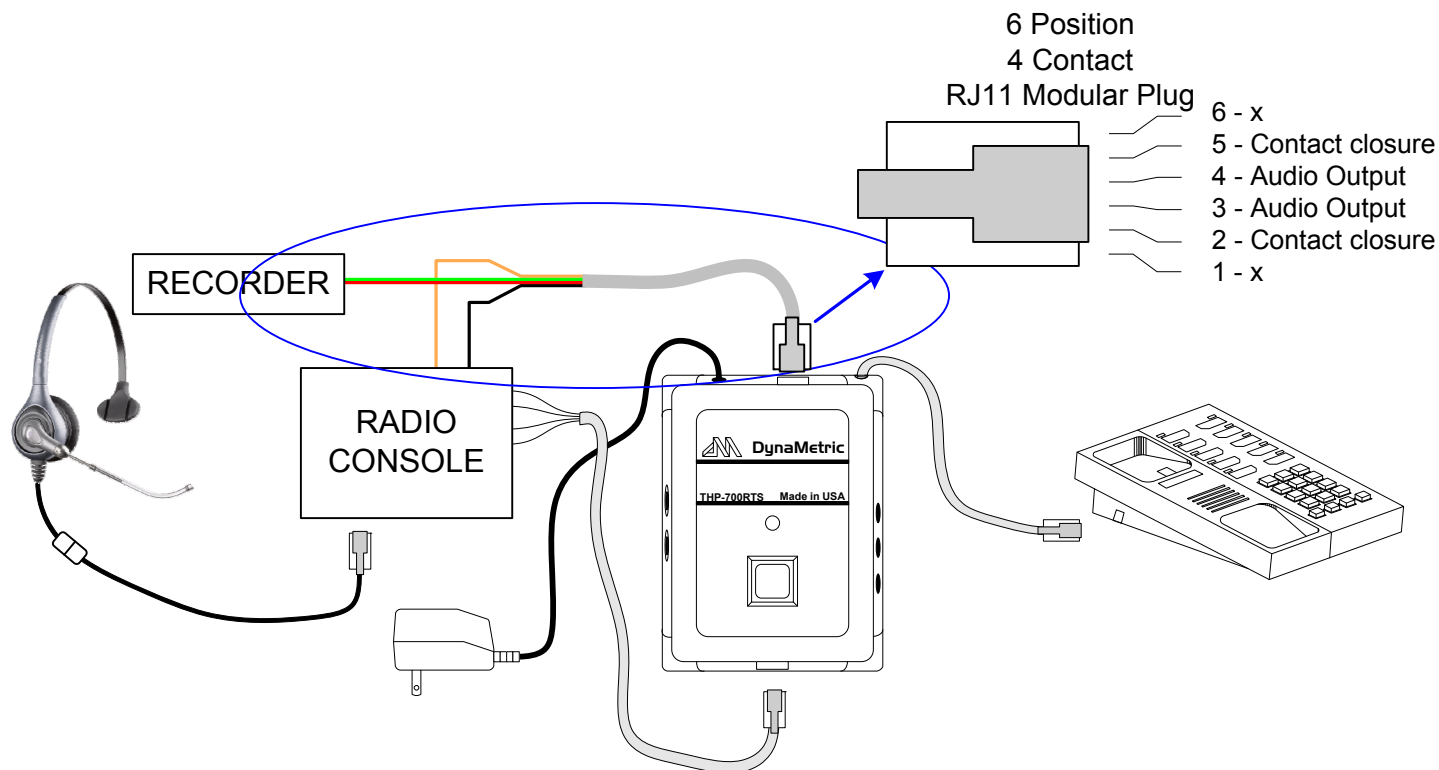

Next an RJ11 cable (6P4C modular) must be made to connect the 700RTS to the radio console and the recorder. The center 2 pins, pins 3&4, carry audio of the phone conversation (but not the radio traffic) from the 700RTS to the recorder. If recording is not needed then no connections to these pins is necessary.

Pins 2&5 connect to contacts inside the 700RTS which short to signal the radio console that the headset connections should be switched to the phone. The 700RTS would do this either because audio was sensed on the phone line or the operator pushed the button on the 700RTS.

Connect pins 2&5 to the input on the radio console that activates the headset switching, which will cause the radio console to connect all 4 wires of the headset to the cable that connects to the bottom jack on the 700RTS.

Plug the 700RTS power supply into 120VAC and the power jack on the 700RTS.

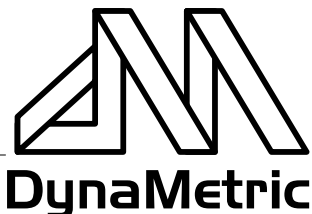

Testing

Push an outside line button on the phone, or whatever button sequence necessary on your particular phone to make a call on an outside line with the headset. This will send dial tone to the earphone lines of the phone's headset jack, which will be detected by the 700RTS. The LED on the 700RTS will come on, and it will short the RJ11 terminals 2&5. This will signal the radio console to connect the 4 headset wires to the cable that plugs into the bottom of the 700RTS, which will in turn connect them to the phone headset jack..

You should be able to hear the dialtone in the headset earphone. If not, you can use a volt meter to see voltage present on the RJ11 pins 2&5 (from the radio console) when the 700RTS LED is off, and that voltage should drop to zero when the LED is ON. If no voltage is present, disconnect the RJ11 plug from the 700RTS and measure again to verify the radio console is supplying voltage. You can also check the 700RTS RJ11 pins 2&5 with an Ohm meter: when the LED is on, the resistance should be less than 5 Ohms, and greater than 100K Ohms with the LED off.

Push whichever single digit on the phone dial pad that will give you silence on the line. With silence in the earphone, you can switch the 700RTS back and forth between phone and radio using the button on the 700RTS.

NOTE: the 700RTS voice detection circuit overrides the push button so that, if there is sound coming from the phone, the 700RTS will stay connected to the phone. This is so the operator will not miss anything from the caller. In most cases, the radio console is wired such that, when the headset is in use by the phone, any radio traffic is switched to the console speaker so the operator will not miss hearing it. The operator may put the call on HOLD with the phone hold button to allow switching to the radio if necessary.

The 700RTS supplies an alert tone (half-second beep) when it switches to the phone line. The loudness is adjustable, including setting it to zero if the alert tone is not wanted.

When no sounds are detected from the phone for about 10 seconds, the 700RTS switches the headset back to radio. The 10 second time interval is adjustable from about 5-30 seconds. The audio detection threshold that the 700RTS switches over to the phone is also adjustable if necessary. See the separate instructions included with the unit.

Whenever the 700RTS LED is on, the phone audio is routed to the RJ11 jack pins 3&4 so it can be recorded.

CHECK OUT THE OTHER MODELS of Radio Telephone Transfer Switches in the THP-700RTS family for different combinations of features at www.dynametric.com

Quick THP-700RTS Checkout & Feature Demonstration

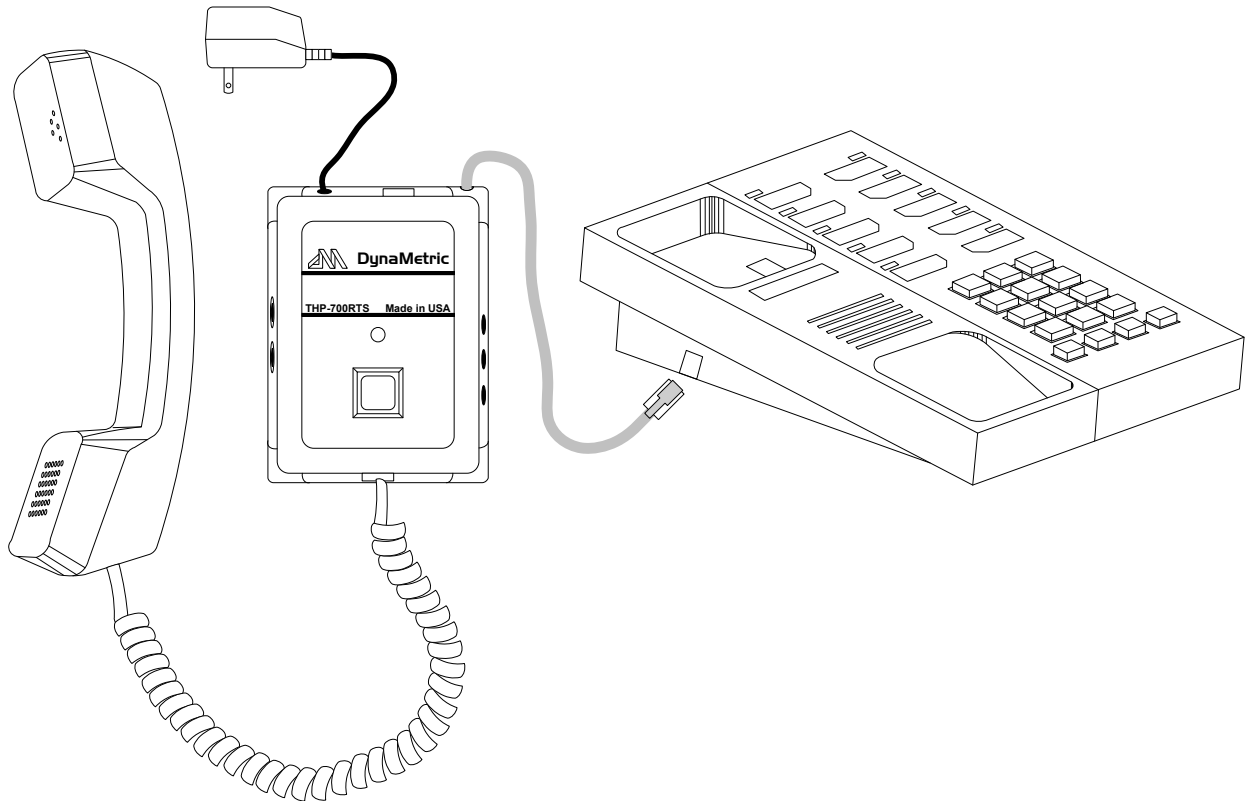

A quick checkout of the THP-700RTS and its features can be done with only the addition of a regular telephone.

Connect the 700RTS to a regular desk phone as shown. Most phones have the correct wiring on their handset to complete this test.

When the connections are complete, lift the receiver. The dialtone will trigger the 700RTS and the LED will come on, the alert tone then the dialtone will be heard in the earphone.

Make a call and verify that both parties hear each other.

While both parties are silent, push the button on the 700RTS to see the switching operation and hear the alert tone each time the 700RTS switches on.

While the LED is off, have the far party speak and the 700RTS will switch back on.

While the LED is off, have the near party only speak and see that the 700RTS does NOT switch on.

While the far party is speaking, push the button and see that the 700RTS will NOT switch off.

If desired, an Ohm meter may be connected to the RJ11 connector pins 2&5 to see the contact closure whenever the LED is on.